



A MAXCESS BRAND

High Accuracy Electromagnetic Radar Sensor for Metals Furnaces

The Fife ExactTrak Radar Sensor delivers high-speed, non-contact center position control for metal strips in high temperature treatment lines. It is a superior performance and reliability alternative to traditional capacitive or inductive sensors used today in continuous process furnaces.

The ExactTrak system features two radar sensors, each mounted outside of the furnace on opposite sides. The sensors emit electromagnetic radar waves through an insulated window onto the edges of the metal strip as it travels through the furnace.

The radar waves reflect off the metal strip back to the sensors' dual receivers, which determine the strip position based on the time it takes for the radar waves to return. Finally, the Fife D-MAXE digital signal processor uses these signals to calculate the center position of the strip, and drives the actuated guide to adjust the lateral strip position in real-time.



Installing ExactTrak is straightforward. An opening on each side of the furnace wall is required, aligned with the position of the metal strip. Furnace windows with non-conductive thermal insulation and mounting flanges are provided, which completely seal the furnace openings and protect the sensors from being damaged by extreme temperatures, contaminants, and contact with the strip. The windows can also be adapted to pre-installed assembly flanges, making it easy to upgrade to higher reliability radar sensor technology without requiring significant mechanical modifications to the furnace.

General Specifications

Weight

70 kg: Including furnace window

Furnace Temperature*

up to 1100 °C

Ambient Operation Temperature:

5° - 70°C (using liquid cooling)

Water Cooling

Max 70 °C

Protection Class

IP64 (Electronic part)

Power Supply

24 VDC

Sampling Rate

1000 Hz / 1 ms

Accuracy/Linearity*

up to ± 1 mm over the entire field of view

Plane Change*

± 60 mm

Strip Thickness Minimum*

0.1 mm

Frequency Range

57 - 64 GHz

Measurement Range*

250 mm to 2000 mm

Certifications

CE

* application dependent

Key Features

- High accuracy
- Not affected by contaminants
- Self-monitoring
- Simple conversion of existing capacitive and inductive sensor installations
- Utilizes 60 GHz frequency, eliminating the need for costly and time consuming on-site EMC certification
- No contact of the antennas with the furnace atmosphere
 - High operational reliability and long life span
 - Easy installation and alignment
 - Simplifies service work
 - Quick replacement without production downtime in most applications

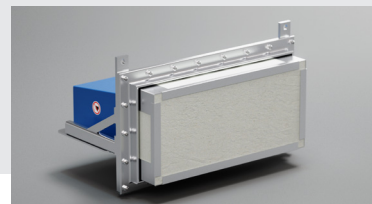

DIMENSIONS

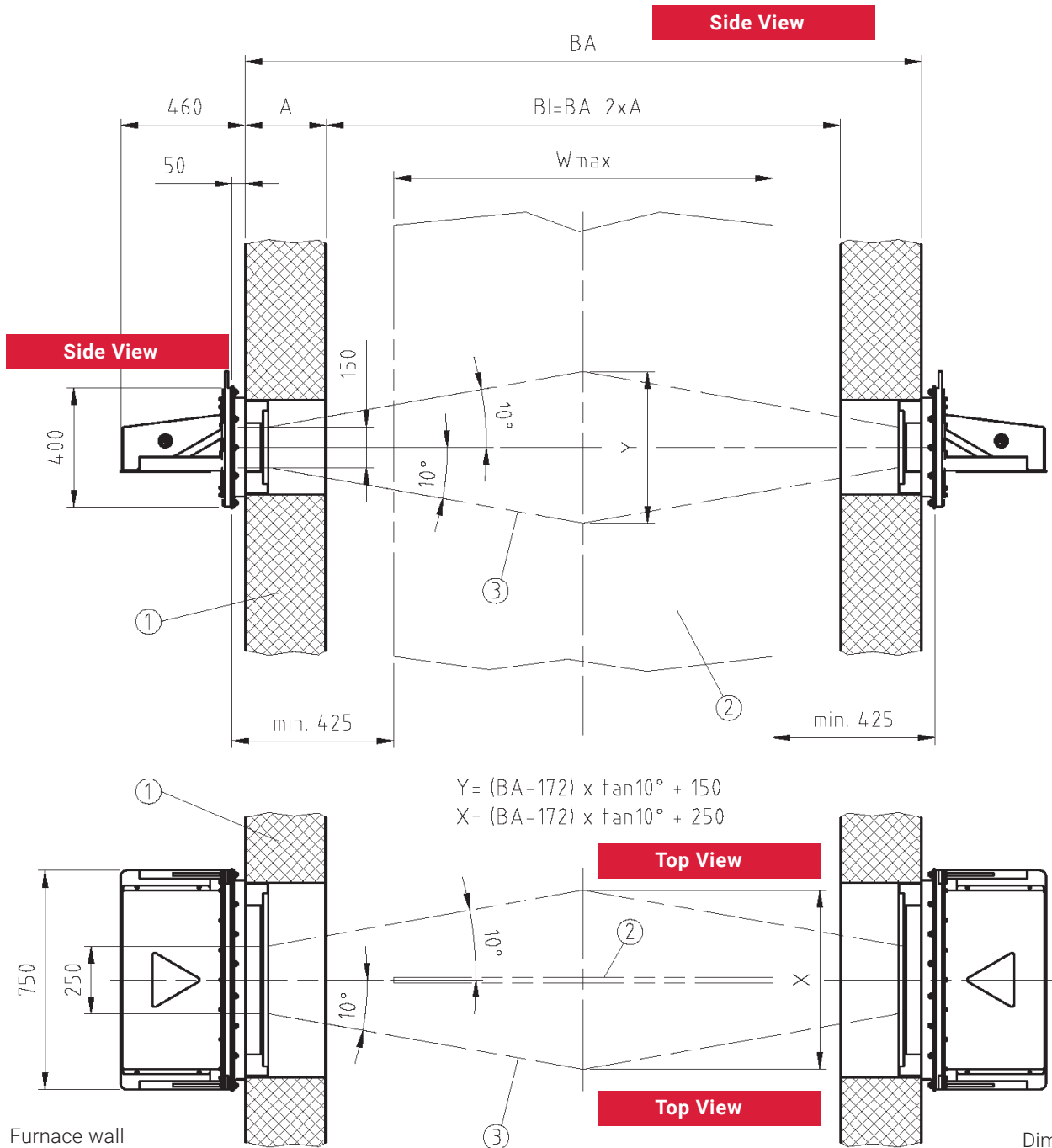

- 1 Furnace wall
- 2 Metallic Strip
- 3 No electrically conductive objects in this area

Dimensions in mm

Subject to change

Global HQ & Americas

+1-844-MAXCESS

sales@maxcessintl.com

Maxcess Europe HQ
Fife-Tidland GmbH

Maxcess Germany
RotoMetrics Deutschland GmbH

Maxcess UK
RotoMetrics Intl. Ltd.

Web
maxcess.com

+49-6195-7002-0
sales@maxcess.eu

+49 6134 7262 - 0
sales@rotometrics.de

+44 1922 6100 00
uk.sales@maxcessintl.com

Shop
mymaxcess.eu
myroto.com

