



A MAXCESS BRAND

## Up To 10X More Accurate Widest Field Of View

The GuideLine digital line sensor detects lines, edges, and graphic patterns, such as bar codes, at a highly competitive price. It performs well in low contrast conditions or with closely spaced patterns where traditional sensors struggle and can edge guide transparent films. The color touch screen interface displays the web in full color, making calibration simple. With a 32 mm wide field of view and high resolution, GuideLine handles the most demanding line guide tasks.

The new GuideLine HR (High Resolution) offers even greater precision, with a resolution of 0.0008 mm—2.5 times higher than GuideLine—making it perfect for applications requiring the highest accuracy and repeatability, including materials used in battery, optical films, black-on-black materials, and fuel cell production.

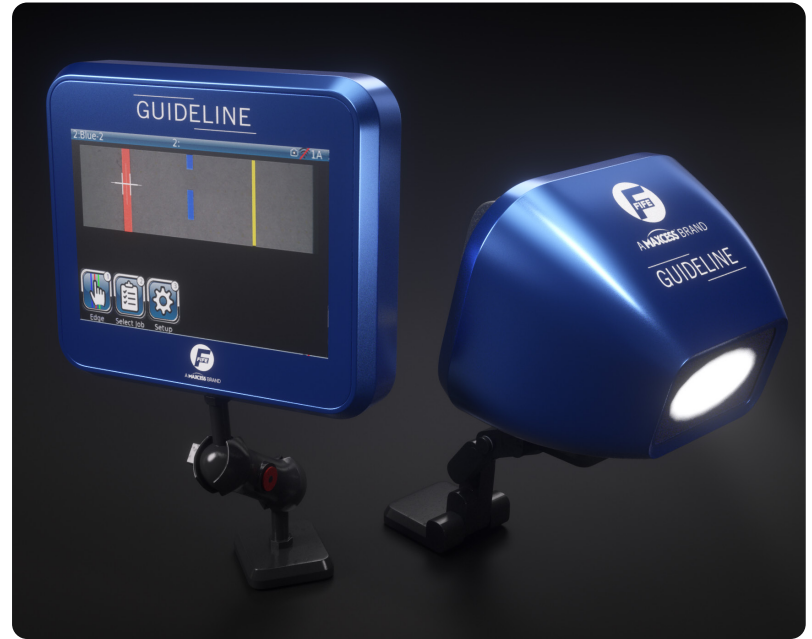

### Key Features

- Standard Guideline resolution: 0.0020mm
- Standard Guideline Sensing Gap: 86mm
- Ability to easily guide to lines, edges of lines and graphic patterns on the fly
- High accuracy
- Color camera with intuitive 5" color touchscreen to easily lock on to lines
- 32 mm field of view, the widest field of view on the market
- Utilizes high-speed industrial camera for high resolution even at higher speeds

### Key Features GuideLine HR

- Analog and digital outputs available
- Articulating arm for easy setup
- Guideline HR resolution: 0.0008mm
- Guideline HR Sensing Gap: 10mm
- Guideline HR Field of View: 15mm
- Sensing Gap gauge provided with sensor for easy set up

### General Specifications

- OI Display
- Color touchscreen
- 800 x 480 pixel
  
- Operating Voltage
- 18 - 26 VDC
  
- Power Consumption
- 13 W maximum
  
- Field of View
- 32 mm
  
- Certifications
- CE
  
- IP Protection Class
- IP54
  
- Temperature
- 0 - 60 °C (32-140° F)
  
- Response Time
- 5 ms

## GUIDELINE SENSOR DIMENSIONS

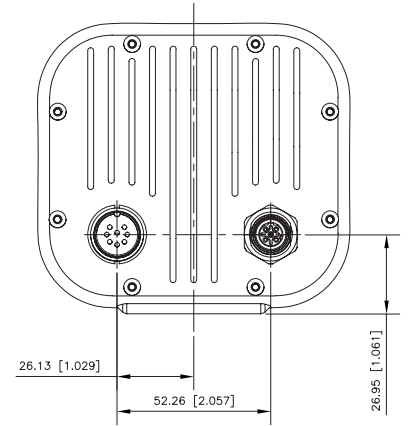
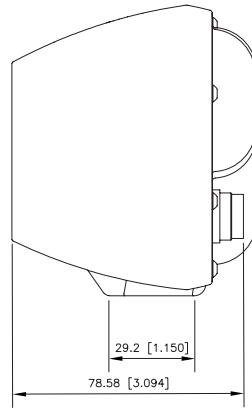
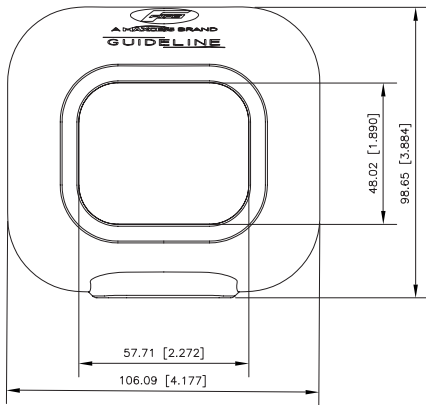
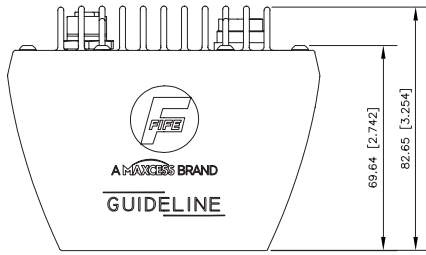

## GUIDELINE OI DIMENSIONS

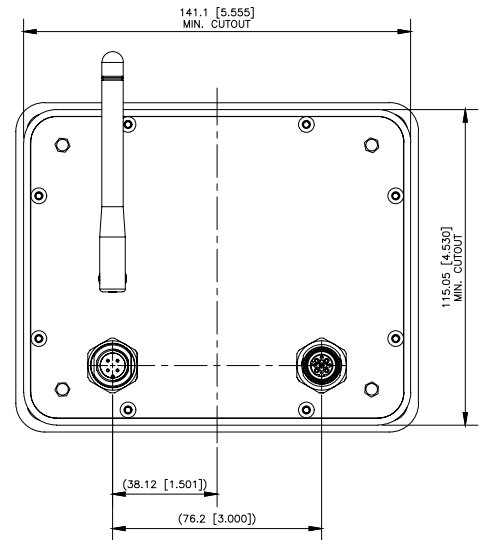
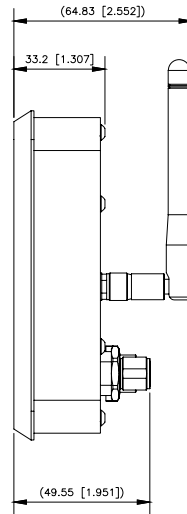
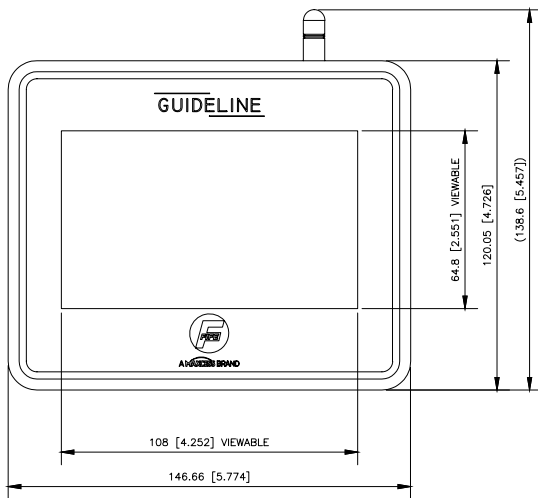

GLOBAL HEADQUARTERS  
& AMERICAS

P +1-844-MAXCESS  
F +1-405-755-8425  
sales@maxcessintl.com

[maxcessintl.com](http://maxcessintl.com)

EUROPE  
& MIDDLE EAST

P +49-6195-7002-0  
F +49-6195-7002-933  
sales@maxcess.eu

[maxcess.eu](http://maxcess.eu)

ASIA  
PACIFIC

P +86-756-881-9398  
F +86-756-881-9393  
info@maxcessintl.com.cn

[maxcessintl.com.cn](http://maxcessintl.com.cn)



RELATED PRODUCTS  
ASK US ABOUT:

Rotometrics Flexible Dies  
FIFE-500 MAX Guide  
Componex AV Idler Rolls

