

# MAXCESS®

FIFE

## FIFE-500 MAX 卷材纠偏系统



A MAXCESS BRAND

### 精度至上

FIFE-500 MAX继承了经典产品FIFE-500 中受用户喜爱的功能项目,并将其进一步优化。

FIFE-500 MAX整机赋予现代美学设计,拥有网络通信功能;配置5英寸彩色触摸屏,支持多种语言;8极电机以实现更平稳顺畅纠偏、更高精度,更少废料;高性价比,利用最新技术提高产品性能并减少维护工作。本产品基于无刷电机和更高性能的处理器的,即使在高速的生产线上,FIFE-500 MAX也可以快速适应卷材变化。

最新产品可用于1200毫米的卷材宽度,张力可达800 N。

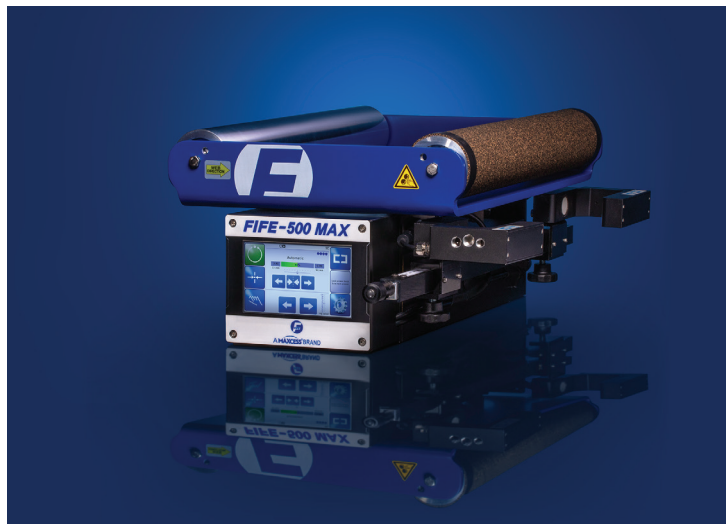

#### 主要特点 规格参数



- 嵌入式通信- Ethernet/IP, CC-Link IEF Basic, Modbus TCP (可选组件 支持PROFINET RT, EtherCAT)
- 更高纠偏精度
- 5英寸彩色触摸屏
- 多语言快速设置和操作, 让操作者快速上手
- 8极无刷电机纠偏更平稳顺畅, 减少废料
- 轻松连接PLC
- 选配接纸台和微调安装支架
- 紧凑设计, 可适用于狭小紧凑的空间

**辊长:**  
最长 1200 mm (47.2 inches)

**最大张力:**  
800 N (180 lbs)

**语言种类:**  
14 种语言可选+1种可定制语言

**跨距:**  
最大 600 mm (23.6 inches)

**IP 保护等级:**  
400N:  
IP64- 标准 / IP65- 可选  
800N:  
IP54

**温度:**  
0-60° C (32-140° F)

## FIFE-500 MAX (400N) 尺寸

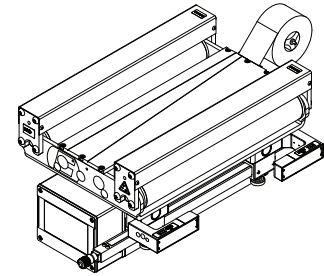
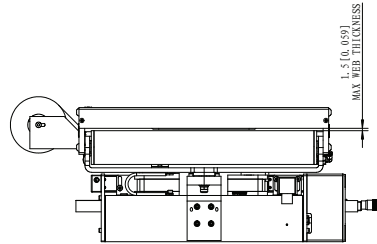
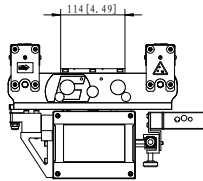
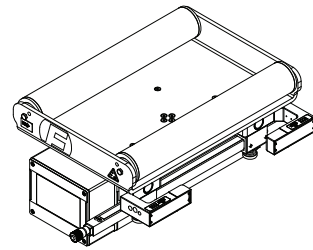
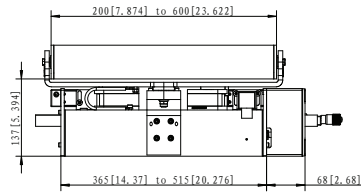
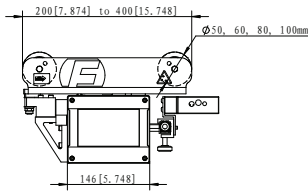

## FIFE-500 MAX (800N) 尺寸

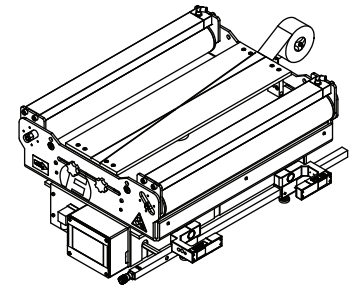
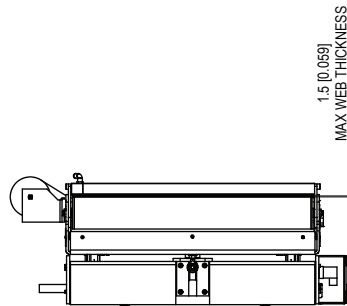
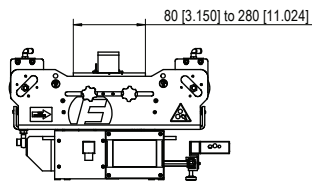
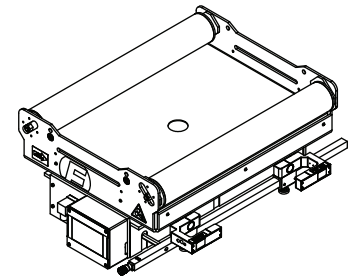
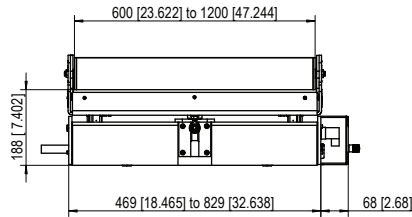
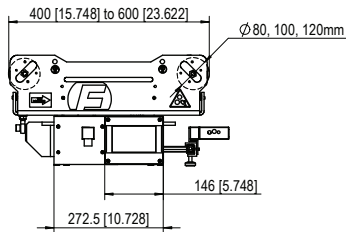

全球总部及美国地区

P +1-844-MAXCESS  
F +1-405-755-8425  
sales@maxcessintl.com  
[maxcess.com](http://maxcess.com)

欧洲和中东地区

P +49-6195-7002-0  
F +49-6195-7002-933  
sales@maxcess.eu  
[maxcess.com](http://maxcess.com)

亚太地区

P +86-400-830-1898  
asia.sales@maxcessintl.com  
[maxcess.com](http://maxcess.com)



了解更多产品::

RotoMetrics Flexible Dies  
MAGPOWR Cygnus  
Componex AV Idler Rolls

