

### TIDLAND CLASS I RIGID CARTRIDGE FOR PERFORMANCE SERIES MANUAL KNIFEHOLDERS

#### High Side Force Slitting for 1-Inch Slit Widths

The Tidland Class I High Side Force (HSF) cartridge for Performance Series Manual knifeholders provides increased side force while maintaining a 1-inch minimum slit width. These rigid cartridges are ideal for narrow slits on materials too thick or dense for the standard Class I. The cartridges can be ordered separately for retrofit in the field, or as part of a new knifeholder assembly.

For easy installation, the Class I HSF cartridge is reversible and interchangeable with the standard shear swing cartridge. Setting the correct blade overlap is simple using the calibrated depth control knob on the Performance Series Manual control body. The pneumatic lock mount, toolless cant angle adjustment, and air-purged, dust-proof design features decrease maintenance and setup times, providing increased productivity and unrivaled finished roll quality.

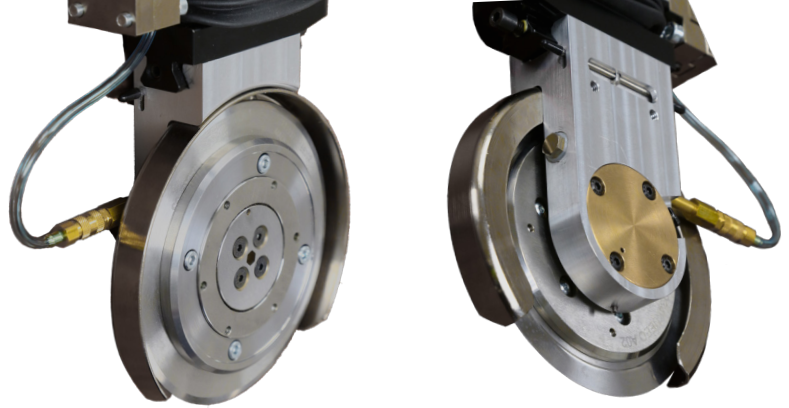

#### GENERAL SPECIFICATIONS

**Type of Slitting**  
shear

**Knifeholder Model**  
Performance Series Manual

**Minimum Slit Width**  
25 mm (1.0 in)

**Blade Diameter**  
90 mm (3.5 in)

**Maximum Speed**  
1,000 mpm (3,500 fpm)

**Side Force**  
~ 30% greater than a standard swing cartridge

#### KEY FEATURES

- Air-purged, dust-proof design
- Calibrated depth knob for precise blade overlap adjustment
- Toolless cant-angle selection
- Reversible, removable blade cartridge, interchangeable with standard version
- Optional pneumatic lock mount with pinion and traverse knob
- Rigid blade cartridge for increased side force (note: rigid cartridge available with manual control body only)

# DESIGN FEATURES

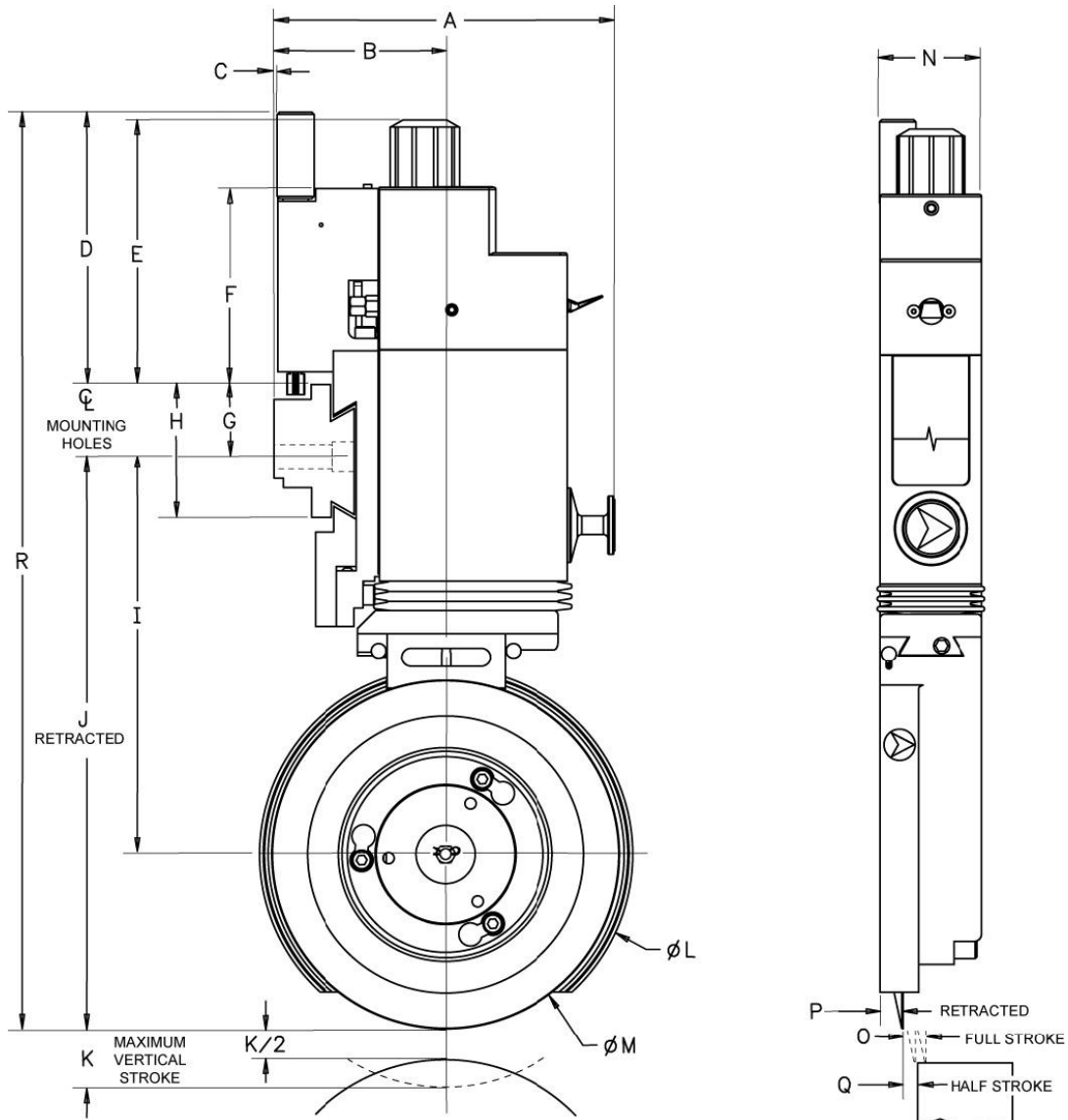

Performance Series Manual Class I Knifeholder with Rigid Blade Cartridge Dimensions

	A	B	C	D	E	F	G	H	I	J	K	L	M	N	O	P	Q	R
MM	120.5	62.5	1.4	97.9	91.7	73.4	26.4	46.8	123.2	168.1	16.0	100	90.0	24.0	3.0	4.8	1.3	292.4
IN	4.74	2.46	0.05	3.86	3.61	2.89	1.04	1.84	4.85	6.62	0.63	3.92	3.54	0.945	0.12	0.19	0.05	11.51



## GLOBAL HEADQUARTERS AND AMERICAS

Tel +1.844.MAXCESS  
Fax +1.405.755.8425  
sales@maxcessintl.com  
www.maxcessintl.com

## EUROPE, MIDDLE EAST, AND AFRICA

Tel +49.6195.7002.0  
Fax +49.6195.7002.933  
sales@maxcess.eu  
www.maxcess.eu

## CHINA

Tel +86.756.881.9398  
Fax +86.756.881.9393  
info@maxcessintl.com.cn  
www.maxcessintl.com.cn

## INDIA

Tel +91.22.27602633  
Fax +91.22.27602634  
india@maxcessintl.com  
www.maxcess.in

## JAPAN

Tel +81.43.421.1622  
Fax +81.43.421.2895  
japan@maxcessintl.com  
www.maxcess.jp

## KOREA, TAIWAN, AND SE EASIA

asia@maxcessintl.com  
www.maxcess.asia

